

4

3

2

1

COVER

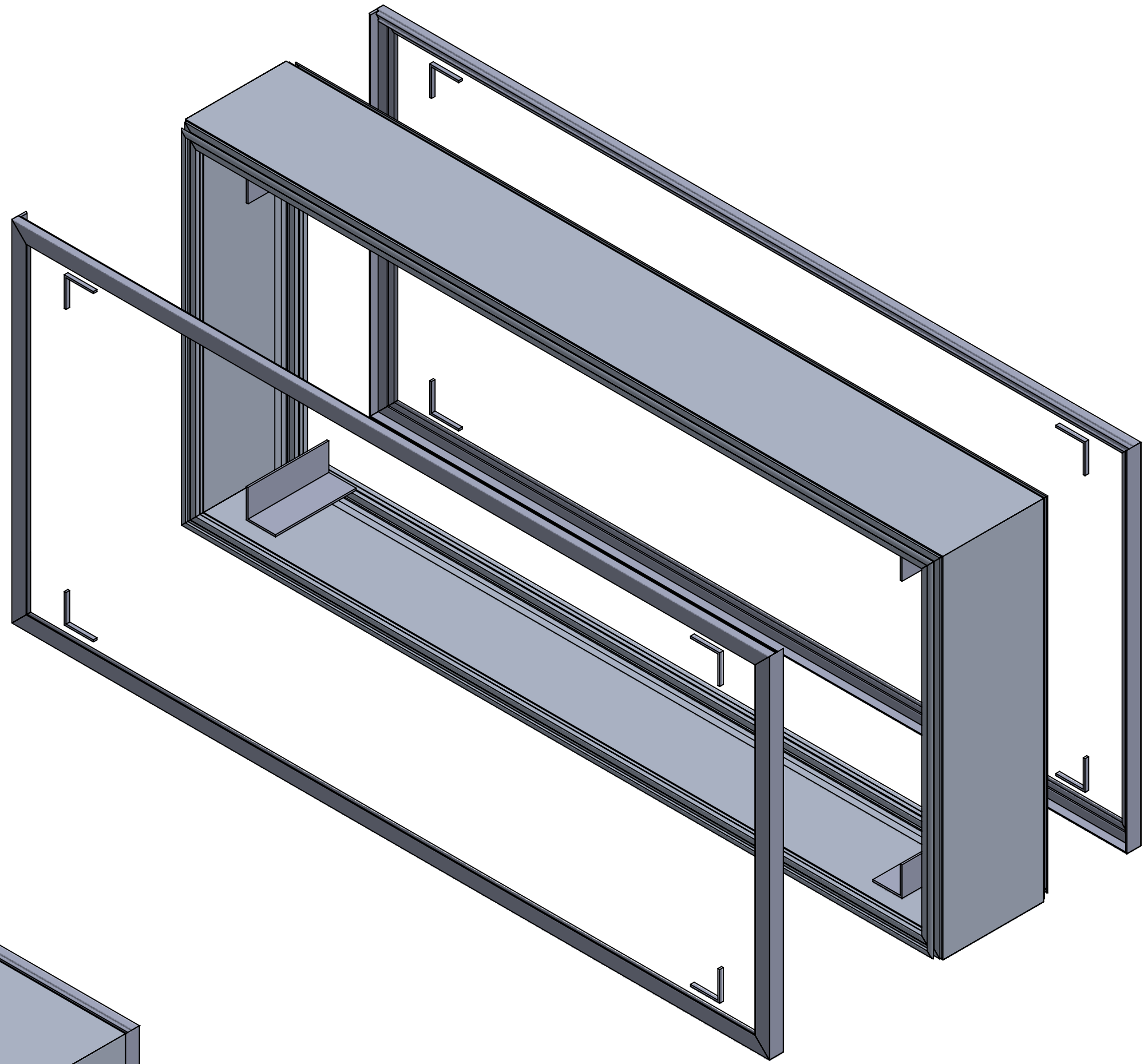
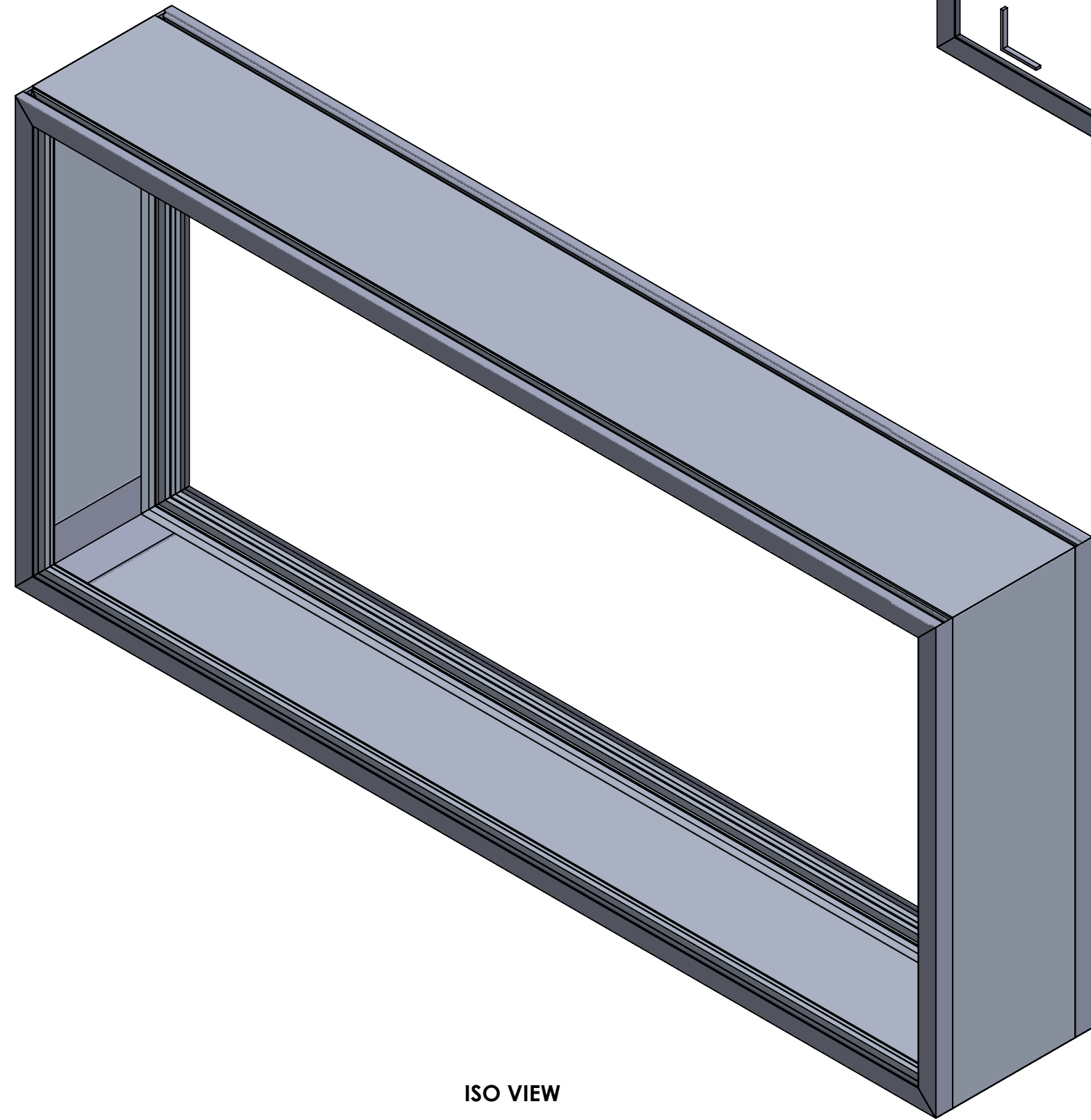

EXCELLART SIGN PRODUCTS, LLC.		UNLESS OTHERWISE SPECIFIED: DIMENSIONS ARE IN INCHES TOLERANCES FRAC = ± 1/32" XXX = ± 0.03 X.XXX = ± 0.010 ANGULAR: MACH ± 1 BEND ± 2		ASSEMBLY ID: ESPH-12-FDF	
1654 S. LONE ELM RD. OLATHE, KS 66061 (800) 627-9044 SALES@EXCELLART.COM WWW.EXCELLART.COM		THE INFORMATION CONTAINED IN THIS DRAWING IS THE SOLE PROPERTY OF EXCELLART SIGN PRODUCTS, LLC. ANY REPRODUCTION IN PART OR AS A WHOLE WITHOUT THE WRITTEN PERMISSION OF EXCELLART SIGN PRODUCTS, LLC IS PROHIBITED.		DESCRIPTION: ESP-12 HINGED W. F RETAINER	
		PROPRIETARY AND CONFIDENTIAL		DRAWN BY: EXCELLART	
				APPROVED BY:	
SIZE	Weight: 66.60	(lbs)	REV		
C	Perimeter Length: 19 (ft)		-		
SCALE: 1:8		1/8/2024		SHEET 1 OF 3	

4

3

2

1

D

D

C

C

B

B

A

A

4

3

2

1

DIMS

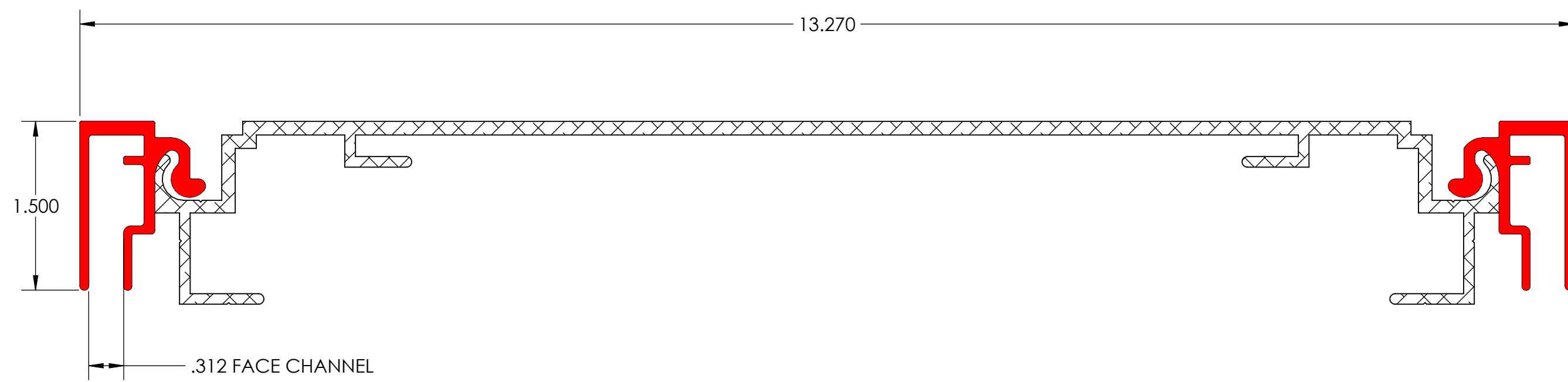
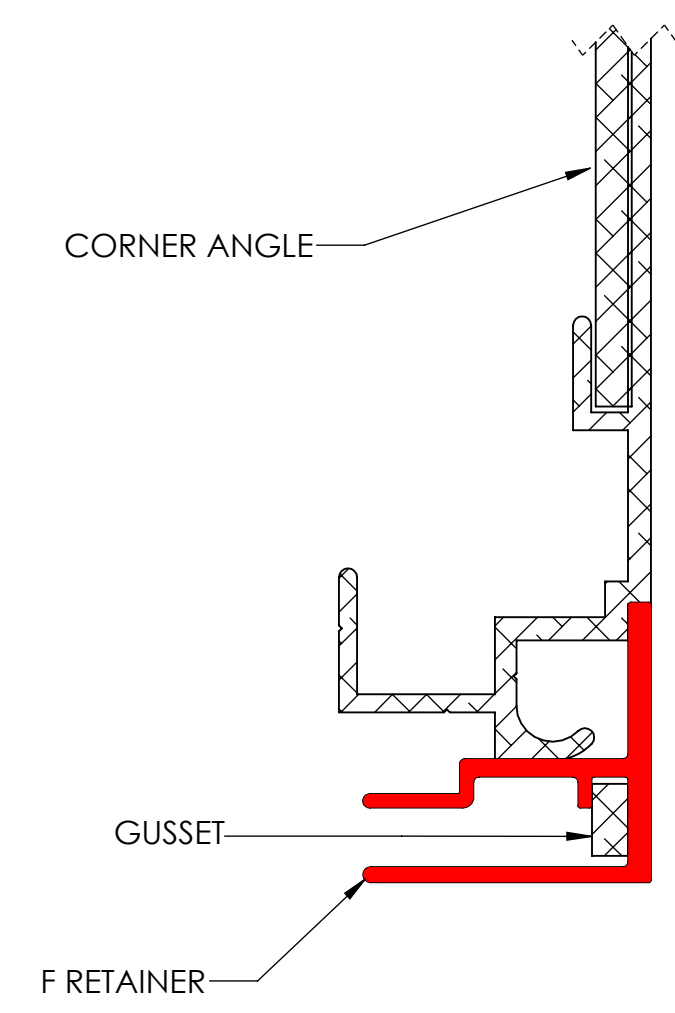
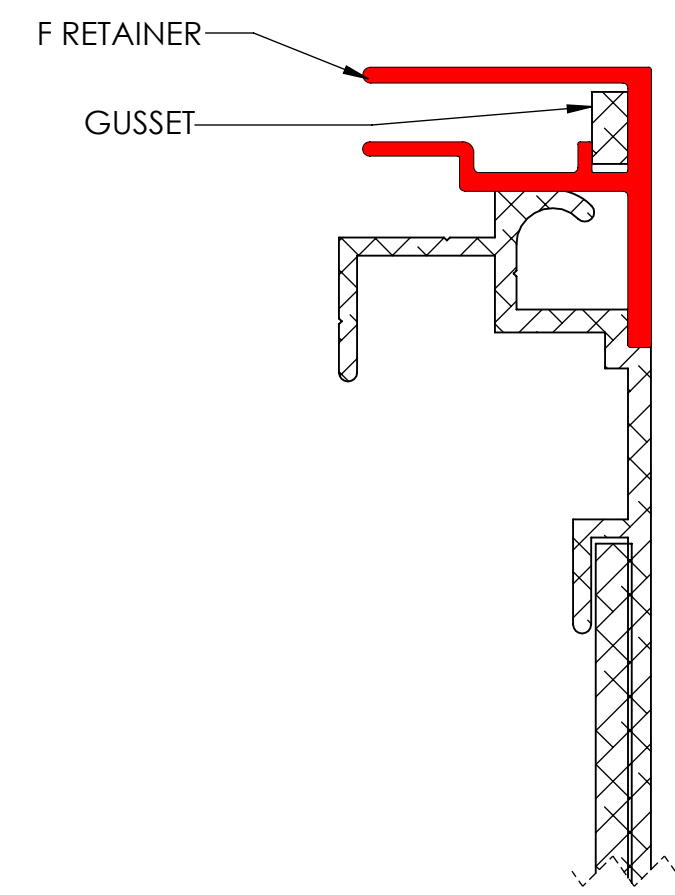
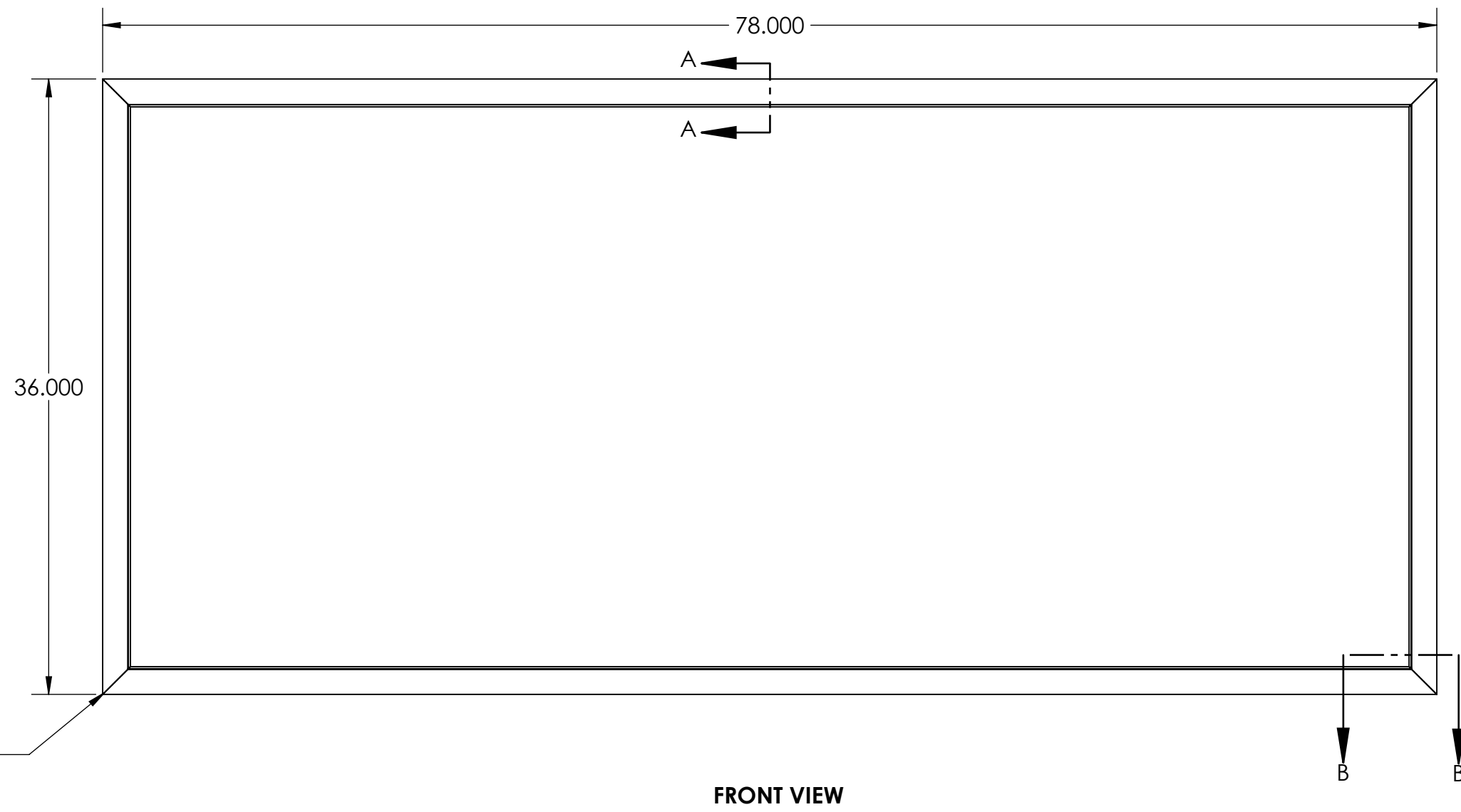

SECTION A-A
ESP-12 HINGED FRAME WITH ESP-F HINGED RETAINERS
SCALE 1 : 1

SECTION B-B
ESP-12 HINGED FRAME WITH ESP-F RETAINERS
SCALE 1 : 1

EXCELLART SIGN PRODUCTS, LLC. 1654 S. LONE ELM RD. OLATHE, KS 66061 (800) 627-9044 SALES@EXCELLART.COM WWW.EXCELLART.COM		UNLESS OTHERWISE SPECIFIED: DIMENSIONS ARE IN INCHES TOLERANCES FRAC = ± 1/32" X.XX = ± 0.03 X.XXX = ± 0.010 ANGULAR: MACH ± 1° BEND ± 2°		ASSEMBLY ID: ESPH-12-FDF	
		THE INFORMATION CONTAINED IN THIS DRAWING IS THE SOLE PROPERTY OF EXCELLART SIGN PRODUCTS, LLC. ANY REPRODUCTION IN PART OR AS A WHOLE WITHOUT THE WRITTEN PERMISSION OF EXCELLART SIGN PRODUCTS, LLC IS PROHIBITED.		DESCRIPTION: ESP-12 HINGED W. F RETAINER	
		DRAWN BY: EXCELLART		APPROVED BY:	
SIZE	Weight: 66.60 (lbs)	REV			
C	Perimeter Length: 19 (ft)	-			
SCALE: 1:8		1/8/2024		SHEET 2 OF 3	

4

3

2

1

D

D

C

C

B

B

A

A

4

3

2

1

BOM

ITEM NO.	PART NUMBER	DESCRIPTION	MATERIAL	QTY.
1	ESP1280202	ESP-12 HINGED FRAME	6063-T6	1
2	ESP1280301	ESP-F RETAINER	6063-T6	2
3	ESP1280302	ESP-F HINGED RETAINER	6063-T6	2
4	ESP1280206	8 5/16" X 3" X 3" X 3/16" ANGLE	6063-T6	4
5	ESP1280185	3/8" X 3" X 3" X 3/16" GUSSET	6063-T6	8

NOTES:

- ESP-12 HINGED KIT CONSISTS OF QTY (4) ESP-12 HINGED FRAME PIECES, QTY (4) CORNER ANGLES, QTY (2) ESP-F HINGED RETAINER PIECES, AND QTY (6) ESP-F RETAINERS PIECES
- ANGLES ARE USED TO GUIDE FRAME PIECES INTO POSITION
- GUSSETS ARE USED TO GUIDE RETAINER PIECES INTO POSITION (IF APPLICABLE)
- HINGED FRAME SECTION AND HINGED RETAINERS SHOWN TO BE ON TOP OF SIGN CABINET (IF APPLICABLE)
- SELF DRILLING SCREWS / RIVETS / LOCK CYLINDERS ETC (BY OTHERS) TO SECURE RETAINERS AS NEEDED
- ANGLES AND GUSSETS TYPICALLY WELDED TO FRAMING (BY OTHERS)
- 6" - 8" CENTER TO CENTER SPACING RECOMMENDED FOR FLEX CLIPS
- PIANO HINGES USED TO ALLOW IDS RETAINERS TO HINGE OPEN (IF APPLICABLE)
- H1 / H1.5 RETAINERS ALLOW SECONDARY FACE TO BE MOUNTED BEHIND PRIMARY FACE
- EXCELLART UL FILE NUMBER: E152309

ISO VIEW
(EXPLODED)

EXCELLART SIGN PRODUCTS, LLC. 1654 S. LONE ELM RD. OLATHE, KS 66061 (800) 627-9044 SALES@EXCELLART.COM WWW.EXCELLART.COM	UNLESS OTHERWISE SPECIFIED: DIMENSIONS ARE IN INCHES TOLERANCES FRAC = ± 1/32" X.XX = ± 0.03 X.XXX = ± 0.010 ANGULAR: MACH ± 1° BEND ± 2°	ASSEMBLY ID: ESPH-12-FDF	
		DESCRIPTION: ESP-12 HINGED W. F RETAINER	
THE INFORMATION CONTAINED IN THIS DRAWING IS THE SOLE PROPERTY OF EXCELLART SIGN PRODUCTS, LLC. ANY REPRODUCTION IN PART OR AS A WHOLE WITHOUT THE WRITTEN PERMISSION OF EXCELLART SIGN PRODUCTS, LLC IS PROHIBITED.		DRAWN BY: EXCELLART	APPROVED BY:
		SIZE C	Weight: 66.60 (lbs) REV Perimeter Length: 19 (ft) -
		SCALE: 1:8	1/8/2024

4

3

2

1