

2

1

NOTES:

- 1) TYP WALL THICKNESS = 0.12" EXCEPT AS NOTED
- 2) 1' LENGTH SHOWN FOR WEIGHT CALCULATIONS

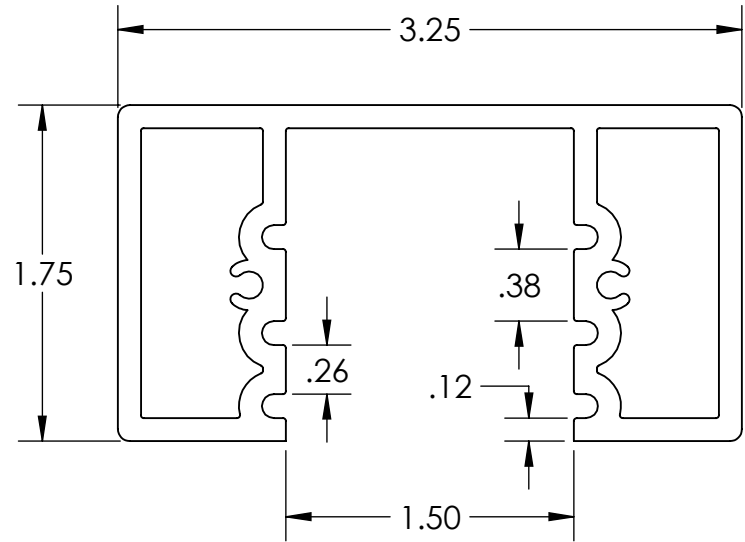

FRONT VIEW

B

B

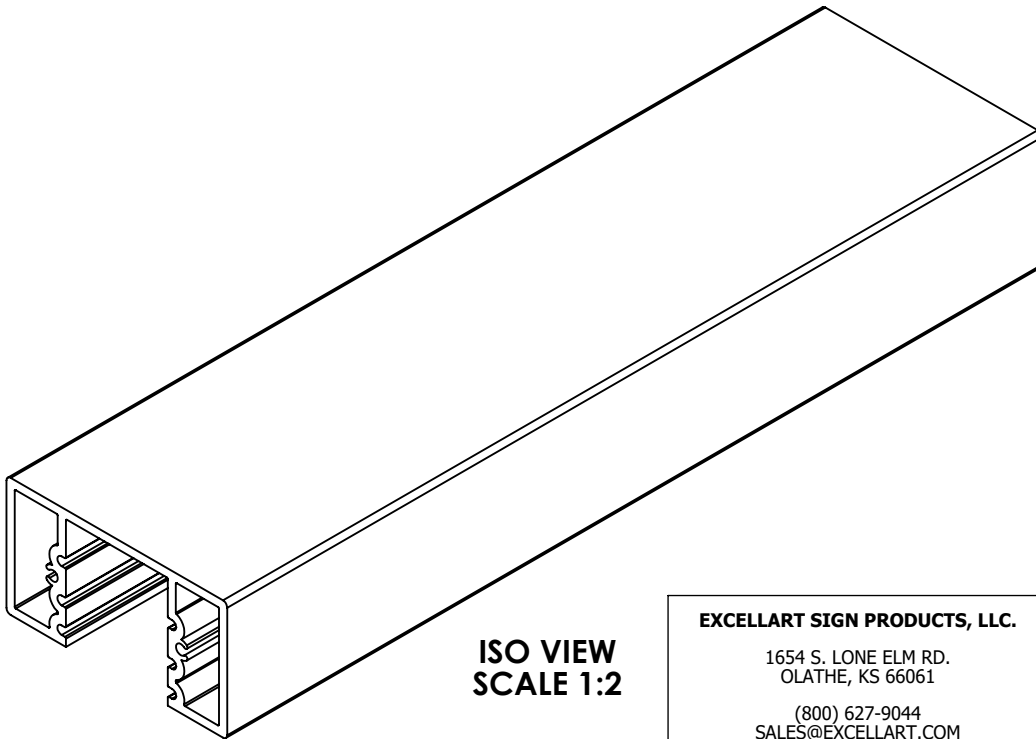

ISO VIEW
SCALE 1:2

A

A

EXCELLART SIGN PRODUCTS, LLC.

1654 S. LONE ELM RD.
OLATHE, KS 66061

(800) 627-9044
SALES@EXCELLART.COM
WWW.EXCELLART.COM



UNLESS OTHERWISE SPECIFIED:

DIMENSIONS ARE IN INCHES
TOLERANCES
FRAC = ±1/32"
X.XX = ±0.03
X.XXX = ±0.010
ANGULAR: MACH±1 BEND ±2

PROPRIETARY AND CONFIDENTIAL

THE INFORMATION CONTAINED IN THIS DRAWING IS THE SOLE PROPERTY OF EXCELLART SIGN PRODUCTS, LLC. ANY REPRODUCTION IN PART OR AS A WHOLE WITHOUT THE WRITTEN PERMISSION OF EXCELLART SIGN PRODUCTS, LLC IS PROHIBITED.

TITLE:

ESP-3.25 RECTANGULAR POST

DESCRIPTION:

ESP1380302

MATERIAL:

6063-T6

DRAWN BY:

EXCELLART

APPROVED BY:

SIZE

A

Weight: **1.69**
pound(s) per foot

REV

-

SCALE: 1:1

1/19/2024

SHEET 1 OF 1

2

1