

2

1

NOTES:

- 1) TYP WALL THICKNESS = 0.08" EXCEPT AS NOTED
- 2) 1' LENGTH SHOWN FOR WEIGHT CALCULATIONS

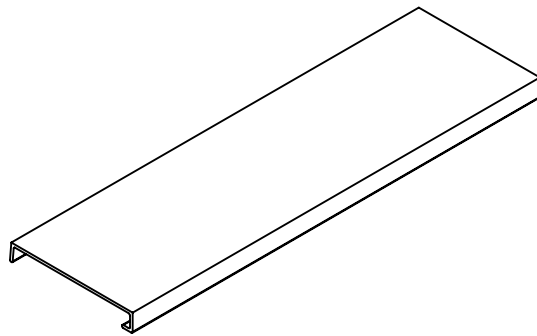

ISO VIEW
SCALE 1:4

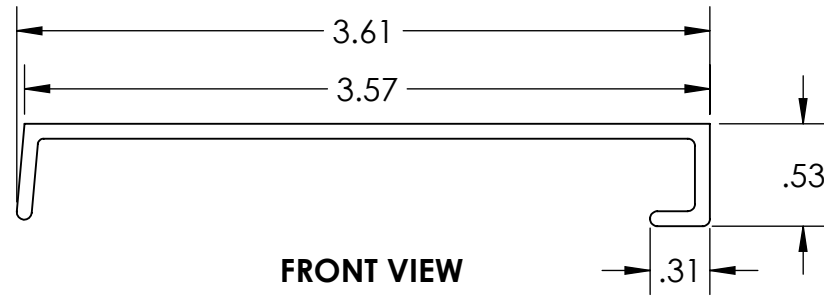

FRONT VIEW

B

B

A

A

EXCELLART SIGN PRODUCTS, LLC.

1654 S. LONE ELM RD.
OLATHE, KS 66061

(800) 627-9044
SALES@EXCELLART.COM
WWW.EXCELLART.COM



UNLESS OTHERWISE SPECIFIED:

DIMENSIONS ARE IN INCHES

TOLERANCES

FRAC = ±1/32"

X.XX = ±0.03

X.XXX = ±0.010

ANGULAR: MACH±1 BEND ±2

PROPRIETARY AND CONFIDENTIAL

THE INFORMATION CONTAINED IN THIS DRAWING IS THE SOLE PROPERTY OF EXCELLART SIGN PRODUCTS, LLC. ANY REPRODUCTION IN PART OR AS A WHOLE WITHOUT THE WRITTEN PERMISSION OF EXCELLART SIGN PRODUCTS, LLC IS PROHIBITED.

TITLE:
CLRW 7 LID

DESCRIPTION:
ESP1401016

MATERIAL:
6063-T6

DRAWN BY:
EXCELLART

APPROVED BY:

| | | |
|----------|---------------------|-----|
| SIZE | Weight: 0.43 | REV |
| A | pound(s) per foot | - |

SCALE: 1:1

12/22/2023

SHEET 1 OF 1

2

1